

BC H9G

A 5 H9F -5 @ "\$%&" HB 'D@5 H98 'G+99@6F ÷ <H: B G<

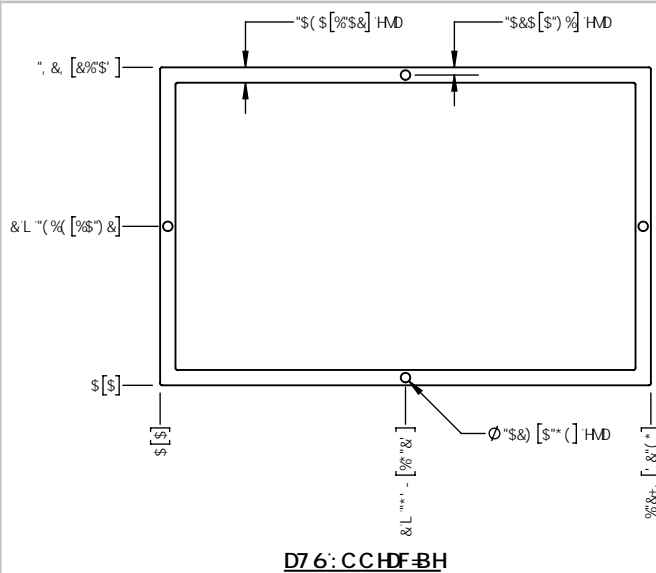
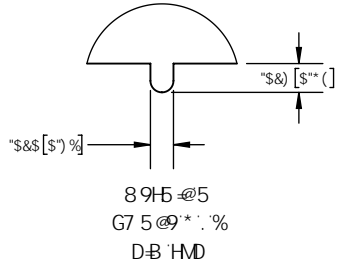
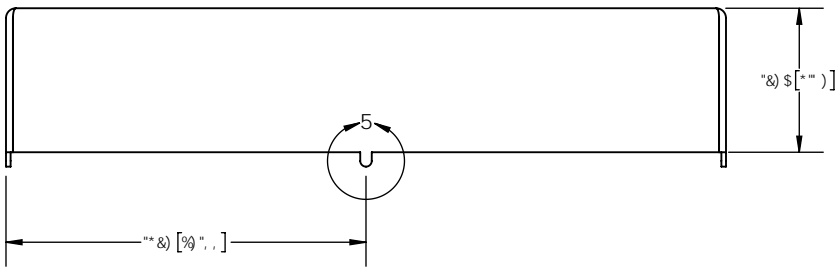
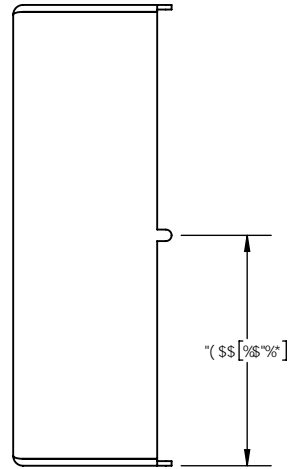
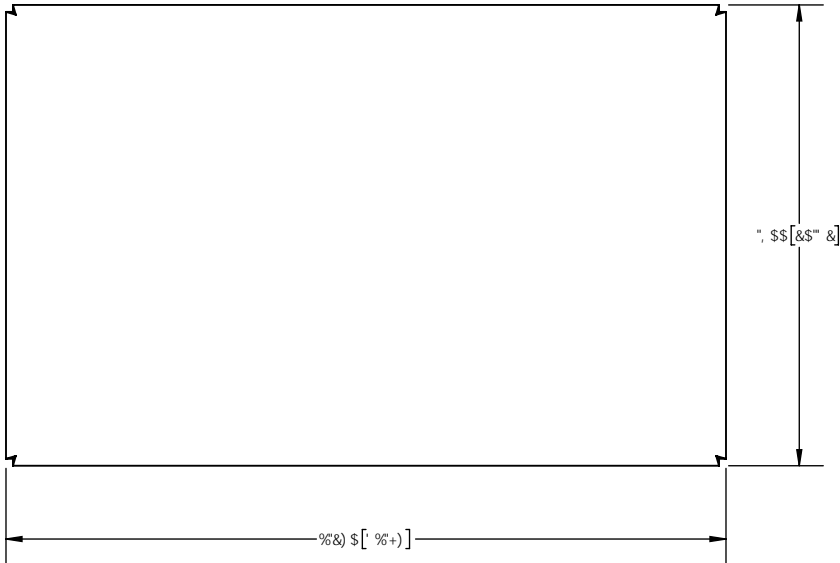
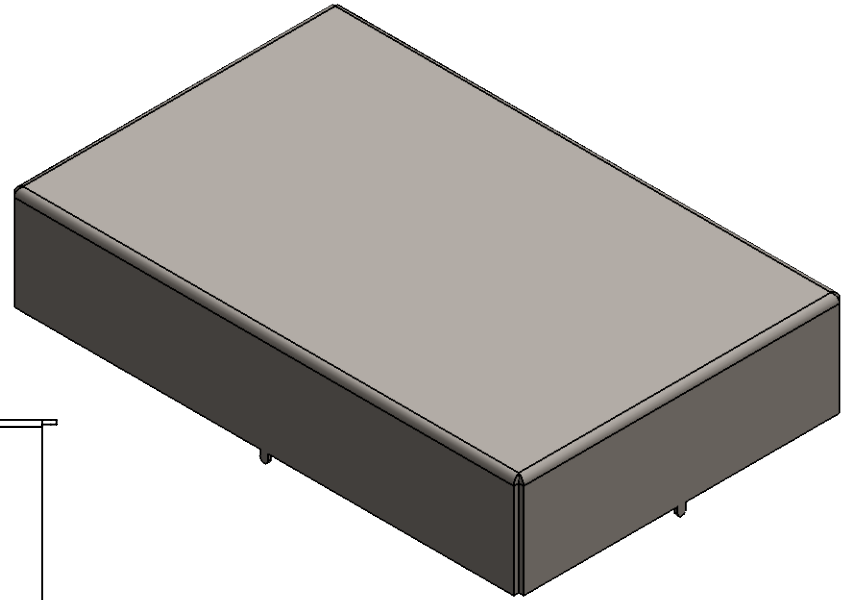

D7.6: CCHDF-BH

PROPRIETARY NOTICE: THESE DRAWINGS, LISTS OR SPECIFICATIONS ARE THE CONFIDENTIAL INFORMATION AND/OR TRADE SECRETS OF 3GMETALWORX INC., AND ISSUED IN STRICT CONFIDENCE. EXCEPT AS AUTHORIZED BY 3GMETALWORX IN WRITING, THESE DRAWINGS, LISTS OR SPECIFICATIONS SHALL NOT BE REPRODUCED, RE-TRANSMITTED, USED FOR THE DESIGN, MANUFACTURE OR SALE OF EQUIPMENT OR USED FOR ANY OTHER PURPOSE OTHER THAN EVALUATION.

IB @9GC H: 9FK 49 CD97 = 98
I #A LC @# SB 7 9
B7 < 9G \$S\$S\$
FC < G
7CA D86 B 7 9
853994* #91



D5FHBI A 69F
E 69 G' \$'
F 91 "
\$
8 9G7 F-DHC B
E I 69
G7.5 @ .015
G< 99H %C : %

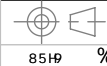

85HP

%!\$%&*

&

%